



DMXPEN

ControlBox

Design your show, record and bring with you



cat.no. dmxpenControlBoxR1-UK-2010

Manual / UK

INDEX

Introduction	page	3
Warnings	page	4
Description	page	5
SetUp / Connections	page	6
Technical Specification	page	7
Input Circuit	page	9
Output Circuit	page	10
PIN Assignment	page	10
Device Configuration	page	12
Remote Control	page	16
Warranty	page	17
Maintenance / Cleaning	page	17

INTRODUCTION

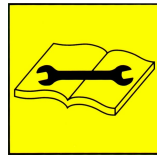

Thanks to buy this DMXPEN series products.
A correct use of this product, will ensure a correct functionality, a long life and at the same time will avoid product failure.

Please read this manual carefully and be sure to understand the information provide to ensure a safe and reliable application, to learn a suitable knowledge of the product and his necessary precaution before using it.

WARNINGS

1. This manual describes the DMXPEN ControlBOX operating functions. The user must operate the product according to the performance specifications described in the operation manuals.
2. While every effort has been made to ensure that the information on this manual is accurate and complete, we would appreciate any errors or omissions submitted to our attention.
3. Maintenance, inspection, and replacement of parts must be performed only by authorized personnel.
4. We reserve the right to change the specifications of the hardware and software described in this manuals at any time and without prior notice.
5. Do not use DMXPEN ControlBOX with wet finger and do not place water on the touch panel.
6. After the package opening, please make this check:
 - The received product correspond with the ordered one.
 - No part are missing on the received product.
 - The product is not damaged.
 - Contact immediately a DMXPen distributor in case of fault.

DESCRIPTION

DMXPen ControlBOX device as the following features:

- DMX512 Signal Recording and Playback
- ArtNet Signal Recording and Playback
- ArtNet → DMX Conversion
- DMX → ArtNet Conversion
- Recording and Playback remote control through ethernet port
- Playback remote control through MIDI port
- Recording and Playback control through touch panel user interface
- On board ROTARY SWITCH and graphic display allow system control and set up
- 8 digital / analog input
- 4 digital output
- 2 analog output
- 2 RS485 port
- 2 RS232 port
- 1 MicroSD card

Briefly the DMXPen products mission is record and carry easily: "*Design your show, record and bring with you*".

Why recording? The first goal of a professional light programmer is to select a light desk and learn to use it in the best way, because this means freedom of expression and productivity.

The DMXPen products range improve this concept taking care of recording what the light programmer realize what his preferred equipment.

Why carry? Often the light programmer presence is not necessary during the show playback, so he can realize the show and record it so the user has only the duty to activate his playback (i.e. fair booth, shop, club, etc.)

Moreover doing this with a normal light desk, mean carry heavy or expensive equipment that usually are not so familiar to the users (i.e. barman, custodian, etc.).

This is another issue improved from the DMXPen products because contains only the show engine with a simple user interface at a very low cost.

SET UP/CONNECTION

Wire the needed line and the power supply on the provided removable connector (be sure that the screw up is correct). Be sure to have the microSD card inserted on the socket (the product is supplied with the microSD card inserted on the socket).

Note: the device do not has a main ON/OFF switch and is necessary remove power supply to make maintenance.

Technical Specification	
Features	<ul style="list-style-type: none"> - 8 digital/analog INPUT - 4 digital OUTPUT - 2 analog OUTPUT - 2 RS485 - 1 MIDI IN - 1 MIDI OUT - 2 RS232 - 1 micro SD Card - 1 Ethernet Port

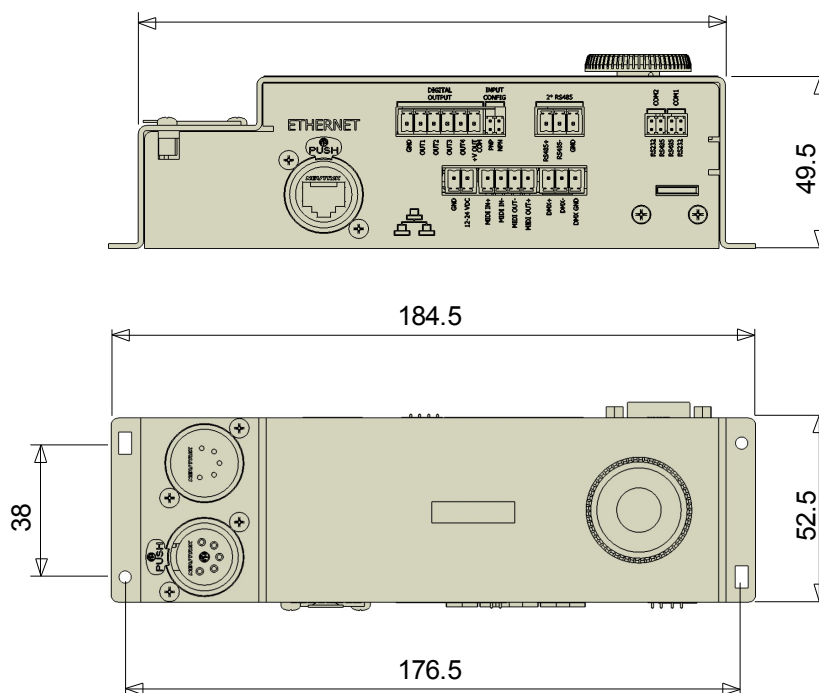

Technical Specification

Dimension (L x W x H)	200 x 160 x 88 mm
Weight	260 gr.
Material / finishing	Aluminium / Black Oxide
Degree protection	IP 30
Operating Relative Humidity :	from 30% to 85% without condensation
Operating Temperature	-5°C + 50°C
DMX IN Connector	5 pole XLR Neutrik male
DMX OUT Connector	X5 pole XLR Neutrik female
Ethernet Connector	RJ45 Neutrik
Power Supply	12-24 VDC – 500 mA
DIGITAL INPUT	<ul style="list-style-type: none"> - NPN/PNP configurable - 24 VDC INPUT max. - 8 channel shared with analog INPUT
ANALOG INPUT	<ul style="list-style-type: none"> - 10 bits converter - 10 VDC INPUT max. - 8 channel shared with digital INPUT
DIGITAL OUTPUT	<ul style="list-style-type: none"> - 4 channel - low RDSon (<0.015 Ohm) mosfet - 24 VDC max. - 20 A max. peak - 4 A max. continuous - current monitor shared with analog INPUT
ANALOG OUTPUT	<ul style="list-style-type: none"> - 2 channel - 8 bits converter - 10 VDC OUTPUT max. - 100 mA OUTPUT max.
RS485	<ul style="list-style-type: none"> - 2 Optocoupled full duplex channel - 500 Mbps max. communication speed - 1 channel shared with RS232
RS232	<ul style="list-style-type: none"> - 2 full duplex channel - 500 Mbps max. communication speed - 1 channel shared with RS485
MIDI	<ul style="list-style-type: none"> - 1 MIDI IN port - 1 MIDI OUT port
MicroSD card	<ul style="list-style-type: none"> - 1 MicroSD card socket - FAT16 file system
Ethernet	<ul style="list-style-type: none"> - IEEE 802.3 10Base – T Ethernet interface
Power supply	<ul style="list-style-type: none"> - 12-24 VDC - 200-500 mA
standard reference	EN 55022, EN 61000-4-2, EN 61000-4-4, EN 61000-4-5, EN 61000-4-6, EN 61000-4-11, EMC 89/336/CEE, BT 73/23/CEE

INPUT CIRCUIT

The analog/digital inputs can be configured as NPN type or PNP type through the on board Input Configuration Jumper. The equivalent input circuits for all 8 input are:

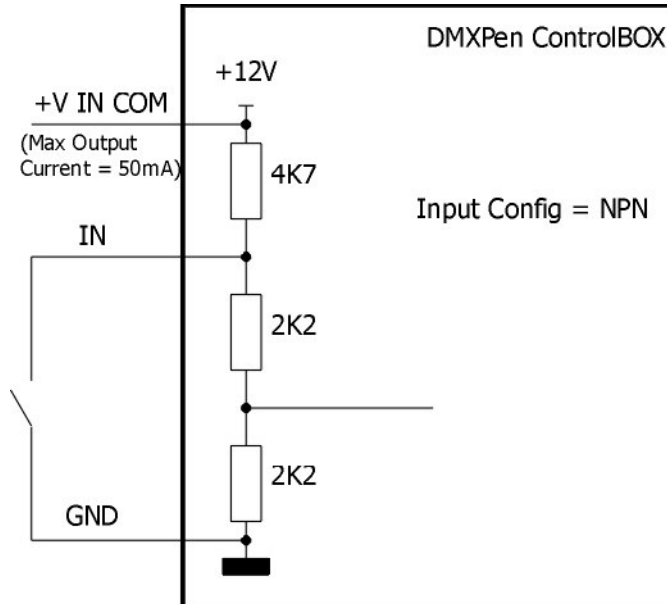

Figure 1: Equivalent Input Circuit with Input Configuration = NPN

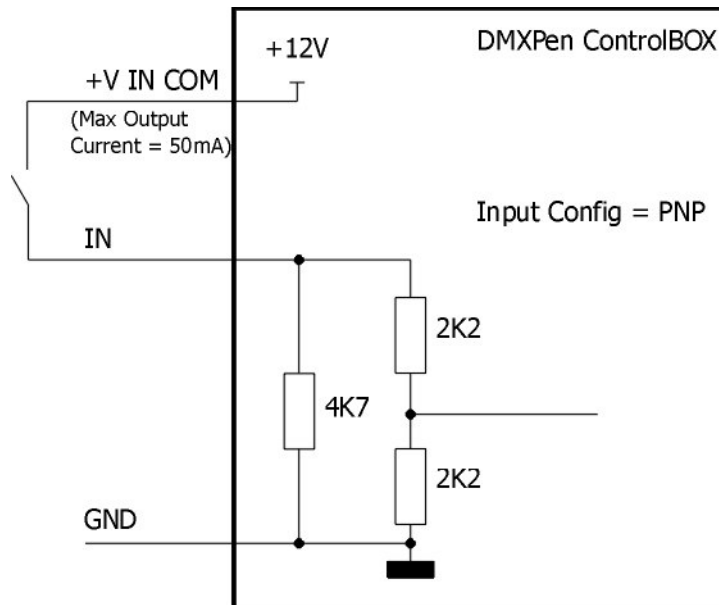

Figure 2: Equivalent Input Circuit with Input Configuration = PNP

OUPUT CIRCUIT

The digital outputs are open drain mosfet and the equivalent output circuits for all 4 output are:

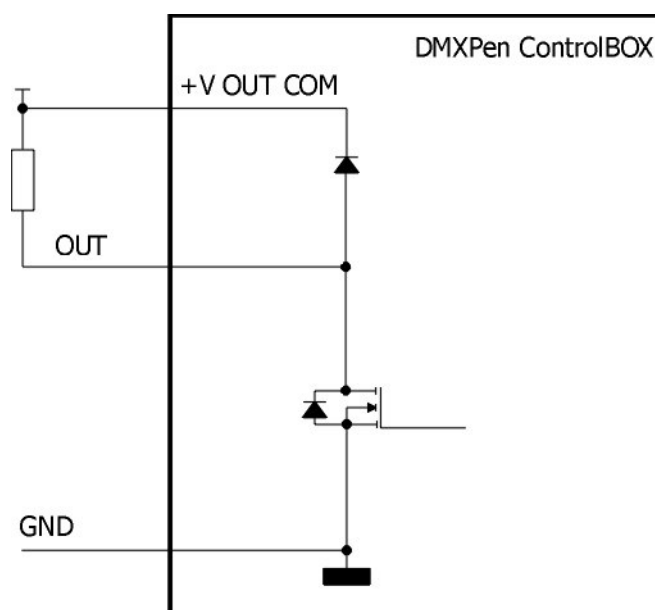

Figure 3: Equivalent Digital Output circuit

A clamp diode for inductive load is internally provided and we suggest to connect the positive load to the +V OUT COM as indicated in the figure above. Maximum positive load voltage is 24VDC.

PIN ASSIGNMENT

Power Supply	
Pin	Description
1	GND
2	12-24VDC

MIDI	
Pin	Description
1	MIDI IN+
2	MIDI IN-
3	MIDI OUT-
4	MIDI OUT+

DMX – SCREW PLUG	
Pin	Description
1	DMX+
2	DMX-
3	GND

2 nd RS485	
Pin	Description
1	RS485+
2	RS485-
3	GND

DIGITAL OUTPUT	
Pin	Description
1	GND
2	OUTPUT 1
3	OUTPUT 2
4	OUTPUT 3
5	OUTPUT 4
6	+V OUT COM

DIGITAL / ANALOG INPUT	
Pin	Description
1	+V IN COM
2	INPUT 1
3	INPUT 2
4	INPUT 3
5	INPUT 4
6	INPUT 5
7	INPUT 6
8	INPUT 7
9	INPUT 8
10	GND

ANALOG OUTPUT	
Pin	Description
1	GND
2	ANALOG OUTPUT 1
3	ANALOG OUTPUT 2
4	+12VDC

RS232	
Pin	Description
1	+5VDC
2	RS232-TX1
3	RS232-RX1
4	
5	GND
6	
7	
8	RS232-TX2
9	RS232-RX2

XLR DMX INPUT	
Pin	Description
1	GND
2	DMX-
3	DMX+

XLR DMX OUTPUT	
Pin	Description
1	GND
2	DMX-
3	DMX+

DEVICE CONFIGURATION

DMXPEN Control Box has an on board user interface provided to configure the device.

This user interface consist in a main page and a configuration menu.

Main Page

Display device activity that can be:

1. ArtNet → DMX Conversion, where the ArtNet frame rate is also indicated (the arrow indicates data flow from ETH port to DMX port)



Figure 4: ArtNet to DMX data direction

2. DMX → ArtNet Conversion, where the DMX frame rate is also indicated (the arrow indicates data flow from DMX port to ArtNet port)



Figure 5: DMX to ArtNet data direction

3. Show Playback, where the frame counter is also indicated
4. Show Recording, where the frame counter is also indicated

Configuration Menu

Menu Level 1	Menu Level 2	Description
PLAYBACK	PLAY START	Allow to select shows and start playback
	PLAY STOP	Stop any playback running
	PLAY MODE	Allow to configure the playback mode between these 2 options: 1. DMX+ARTNET (the show playback frames are transmitted on both DMX and ArtNet port) 2. DMX ONLY (the show playback frames are transmitted on DMX port only)
	POWER ON MODE	Allow to configure the power on behaviour between these 3 options: 1. NO SHOW (at power on ControlBOX perform ArtNet to DMX or DMX to ArtNet conversion regarding the data flow setup. No playback is activated before any user or I/O request) 2. LAST SHOW (at power on ControlBOX start playback of the last show started before power off. This constrain ControlBOX to store on each playback start action the show number on the internal EEPROM. Remember that this memory area can be writed 10,000 times) 3. SELECTED SHOW (at power on ControlBOX starts the

		default show number configured on POWER ON SHOW menu option)
	POWER ON SHOW	Allow to setup the default show number
RECORDING	DMX RECORD	Select DMX port as record source, ask for the show number selection and starts recording. During recording operation the frame counter was displayed on the on board LCD
	ARTNET RECORD	Select ArtNet port as record source, ask for the show number selection and starts recording. During recording operation the frame counter was displayed on the on board LCD
SHOW INPUT 1	SET SHOW N.	Allow to configure the show number to playback on each digital input 1 rising edge
	LOOP ENABLE	Allow to configure the show playback loop behaviour between these 2 options: 1. LOOP ENABLE (with these configuration, each time the last recorded frame is transmitted, the show playback restart from the first one) 2. LOOP DISABLE (with these configuration, when the last frame recorded is transmitted, the playback stops and ControlBOX transmit the last frame up to any new user or I/O event)
SHOW INPUT 2	SET SHOW N.	Allow to configure the show number to playback on each digital input 2 rising edge
	LOOP ENABLE	Allow to configure the show playback loop behaviour between these 2 options: 1. LOOP ENABLE (with these configuration, each time the last recorded frame is transmitted, the show playback restart from the first one) 2. LOOP DISABLE (with these configuration, when the last frame recorded is transmitted, the playback stops and ControlBOX transmit the last frame up to any new user or I/O event)
SHOW INPUT 3	SET SHOW N.	Allow to configure the show number to playback on each digital input 3 rising edge
	LOOP ENABLE	Allow to configure the show playback loop behaviour between these 2 options: 1. LOOP ENABLE (with these configuration, each time the last recorded frame is transmitted, the show playback restart from the first one) 2. LOOP DISABLE (with these configuration, when the last frame recorded is transmitted, the playback stops and ControlBOX transmit the last frame up to any new user or I/O event)
SHOW INPUT 4	SET SHOW N.	Allow to configure the show number to playback on each digital input 4 rising edge
	LOOP ENABLE	Allow to configure the show playback loop behaviour between these 2 options: 1. LOOP ENABLE (with these configuration, each time the last recorded frame is transmitted, the show playback restart from the first one) 2. LOOP DISABLE (with these configuration, when the last frame recorded is transmitted, the playback stops and

		ControlBOX transmit the last frame up to any new user or I/O event)
SHOW INPUT 5	SET SHOW N.	Allow to configure the show number to playback on each digital input 5 rising edge
	LOOP ENABLE	Allow to configure the show playback loop behaviour between these 2 options: 1. LOOP ENABLE (with these configuration, each time the last recorded frame is transmitted, the show playback restart from the first one) 2. LOOP DISABLE (with these configuration, when the last frame recorded is transmitted, the playback stops and ControlBOX transmit the last frame up to any new user or I/O event)
SHOW INPUT 6	SET SHOW N.	Allow to configure the show number to playback on each digital input 6 rising edge
	LOOP ENABLE	Allow to configure the show playback loop behaviour between these 2 options: 1. LOOP ENABLE (with these configuration, each time the last recorded frame is transmitted, the show playback restart from the first one) 2. LOOP DISABLE (with these configuration, when the last frame recorded is transmitted, the playback stops and ControlBOX transmit the last frame up to any new user or I/O event)
SHOW INPUT 7	SET SHOW N.	Allow to configure the show number to playback on each digital input 7 rising edge
	LOOP ENABLE	Allow to configure the show playback loop behaviour between these 2 options: 1. LOOP ENABLE (with these configuration, each time the last recorded frame is transmitted, the show playback restart from the first one) 2. LOOP DISABLE (with these configuration, when the last frame recorded is transmitted, the playback stops and ControlBOX transmit the last frame up to any new user or I/O event)
SHOW INPUT 8	SET SHOW N.	Allow to configure the show number to playback on each digital input 8 rising edge
	LOOP ENABLE	Allow to configure the show playback loop behaviour between these 2 options: 1. LOOP ENABLE (with these configuration, each time the last recorded frame is transmitted, the show playback restart from the first one) 2. LOOP DISABLE (with these configuration, when the last frame recorded is transmitted, the playback stops and ControlBOX transmit the last frame up to any new user or I/O event)
DMXADR OUT 1		Allow to configure the source channel address for the PWM duty cycle of the digital output 1 from the current DMX frame (DMX Input port, ArtNet port or show playback source independently)
DMXADR OUT 2		Allow to configure the source channel address for the PWM duty cycle of the digital output 2 from the current DMX frame (DMX Input port, ArtNet port or show playback source

		independently)
DMXADR OUT 3		Allow to configure the source channel address for the PWM duty cycle of the digital output 3 from the current DMX frame (DMX Input port, ArtNet port or show playback source independently)
DMXADR OUT 4		Allow to configure the source channel address for the PWM duty cycle of the digital output 4 from the current DMX frame (DMX Input port, ArtNet port or show playback source independently)
DMXADR DAC 1		Allow to configure the source channel address for the analog output 1 from the current DMX frame (DMX Input port, ArtNet port or show playback source independently)
DMXADR DAC 2		Allow to configure the source channel address for the analog output 2 from the current DMX frame (DMX Input port, ArtNet port or show playback source independently)
DMXADR STR 1		Allow to configure the source channel address for the serial string command 1 from the current DMX frame (DMX Input port, ArtNet port or show playback source independently)
DMXADR STR 2		Allow to configure the source channel address for the serial string command 2 from the current DMX frame (DMX Input port, ArtNet port or show playback source independently)
DMXADR STR 3		Allow to configure the source channel address for the serial string command 3 from the current DMX frame (DMX Input port, ArtNet port or show playback source independently)
DMXADR STR 4		Allow to configure the source channel address for the serial string command 4 from the current DMX frame (DMX Input port, ArtNet port or show playback source independently)
DMXADR STR 5		Allow to configure the source channel address for the serial string command 5 from the current DMX frame (DMX Input port, ArtNet port or show playback source independently)
DMXADR STR 6		Allow to configure the source channel address for the serial string command 6 from the current DMX frame (DMX Input port, ArtNet port or show playback source independently)
DMXADR STR 7		Allow to configure the source channel address for the serial string command 7 from the current DMX frame (DMX Input port, ArtNet port or show playback source independently)
DMXADR STR 8		Allow to configure the source channel address for the serial string command 8 from the current DMX frame (DMX Input port, ArtNet port or show playback source independently)
INPUT STATUS		Display the current digital input status
SOFTWARE VER		Display the current software version

REMOTE CONTROL

DMXPen ControlBOX is provided with the standard DMXPen engine that allow remote control through MIDI interface or PenSuite software tools (PenSuite is a free software tools available on the device micorSD card or on www.dmxpen.com web site in both PC and MAC OS version).

WARRANTY

2 month

(according to D.L. n.24 2 february2002, directive 1999/44/CE of European Parliament)

MAINTENANCE / CLEANING

No special maintenance operation are required for DMXPEN ControlBOX.

Anyway remember to unplug the device from the power supply during maintenance and cleaning operation.

Moreover we suggest to make a backup copy of the show file stored on the microSD card using a PC connected or other card reader device.

Use only dry cleaning cloth to clean DMXPen ControlBOX. Do not use cleaning solvent or washing powder.

www.dmxpen.com



DMXPEN

Design your show, record and bring with you



www.esta.org



www.ArtisticLicence.com
*Designed by and Copyright
Artistic Licence (UK) Ltd.*